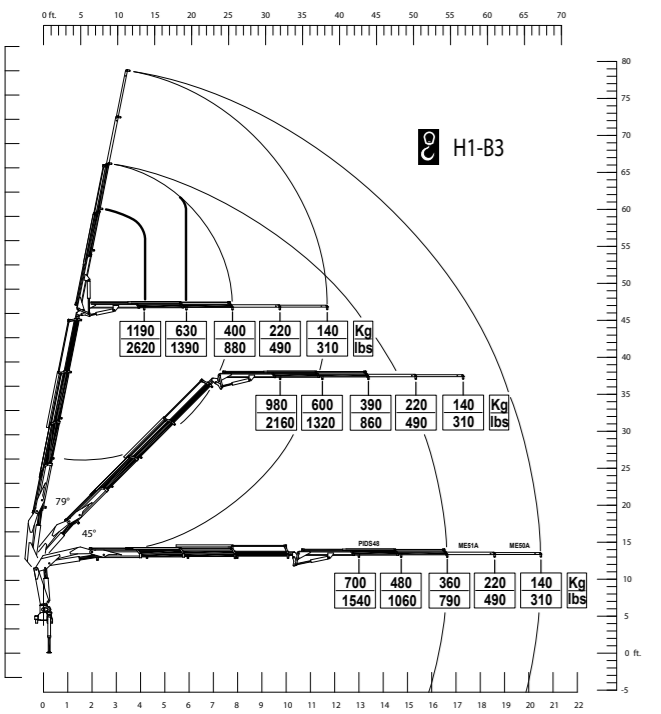
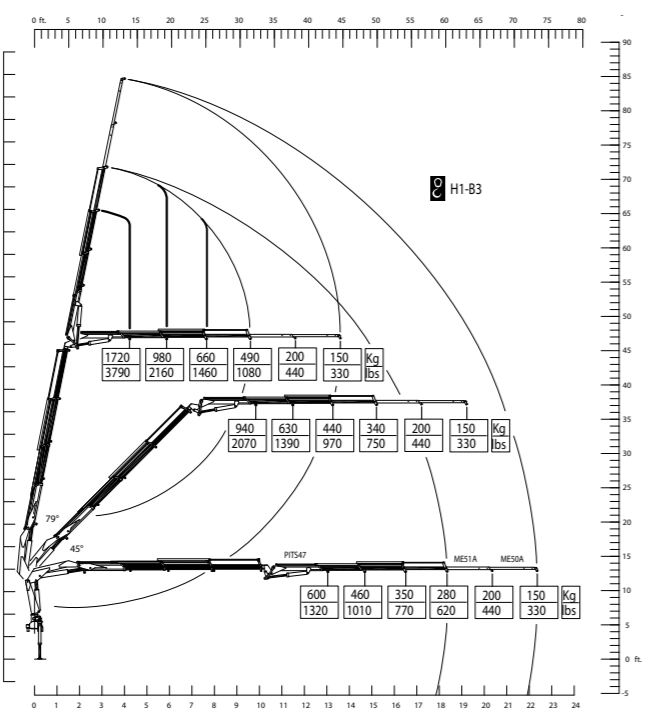
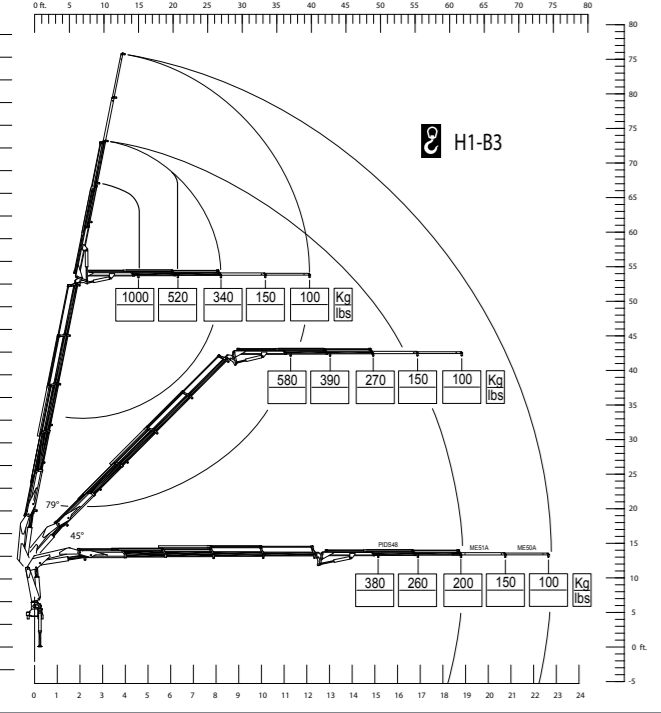
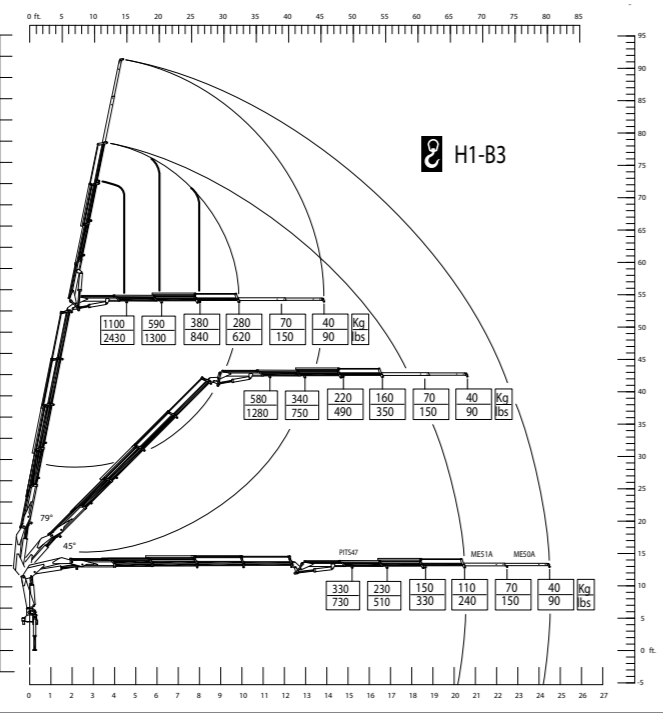

180.3J2**180.3J3****180.4J2****180.4J3**

I Versione std.:C e idraulico_Limitatore di momento_Comandi bilaterali in basso_Rotazione con cilindri e cremagliera_Bracci esagonali_Cilindri di stilo indipendenti_Piedi orientabili a estrazione manuale_Norme DIN 15018 H1B3

GB Std. version:H ydraulic Ce safety device_Load limiting device_Bilateral low controls_Slewing system with cylinders and rack_Hexagonal booms_Independent extension cylinders_Foldable stabilizers with manual extension_Standards DIN 15018 H1B3

F Version standard: Dispositif Ce hydraulique_Limiteur de moment_Commandes bilatérales en bas_Système de rotation avec cylindres et crémaillère_Bras hexagonales_Vérins d'extension indépendants_Pieds relevables avec extension manuelle_Normes DIN 15018 H1B3

D Std. Ausführung:H hydraulische Ce Vorrichtung_Drehmomentbegrenzer_Beidseitige Steuerungen unten_Schwengung mit Zylinder und Zahnstange_Sechskantige Arme_Unabhängige Ausschubzylinder_Hochdrehbare Abstützungen mit mech. Ausdehnung_Normen DIN 15018 H1B3

SP Versión standard: Dispositivo Ce hidráulico_Limitador de momento_Mando bilaterales por bajo_Sistema de giro con cilindros y cremallera_Brazos hexagonales_Cilindros de extensión independientes_Gatos de apoyo rotativos con extensión manual_Normas DIN 15018 H1B3

P Versão standard:D ispositivo Ce hidráulico_Limitador de momento_Comandos bilaterais abaixo_Rotação com cilindros e cremalheira_Braços hexagonais_Cilindros de extensão independentes_Estabilizadores rotativos com extensão manual_Normas DIN 15018 H1B3

power & technology
gru_truck cranes



www.copma2000.com

Std _ **180**



gru_truck cranes



power & technology

- ▶ Scheda tecnica
- ▶ Fiche technique
- ▶ Technische daten
- ▶ Technical features
- ▶ Ficha tecnica
- ▶ Folha de dados

COPMA 2000 SPA - V. EMILIA 281 - 48014 CASTEL BOLOGNESE (RA) - ITALY
Tel +39.0546.653.711 - Fax +39.0546.656.205 e-mail: info@copma2000.com

10/2010

180.1

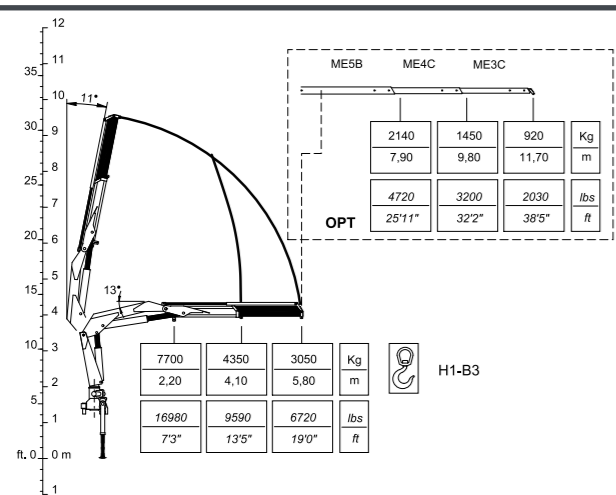

180.3

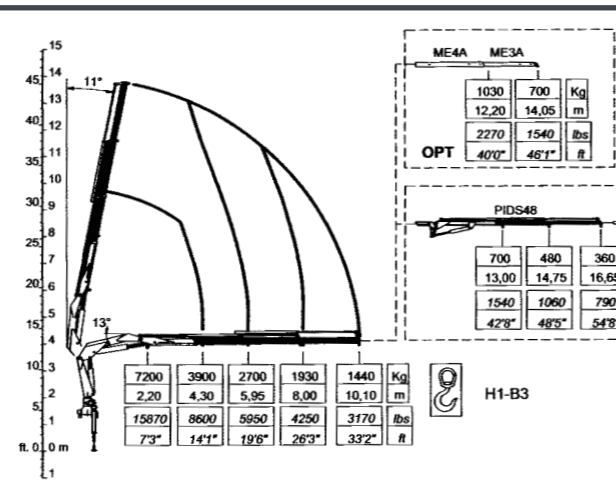

180.2

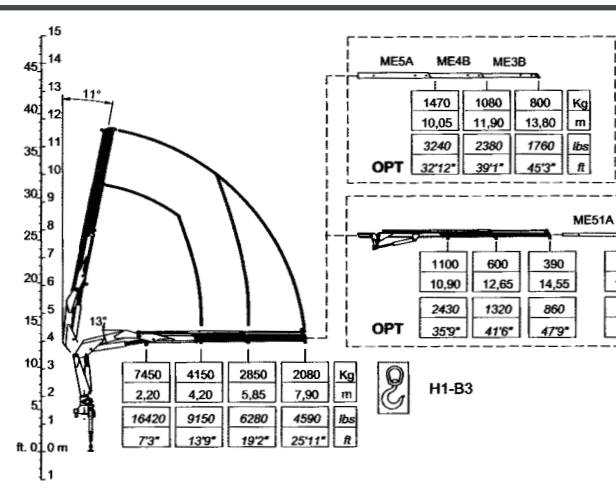

180.3SC

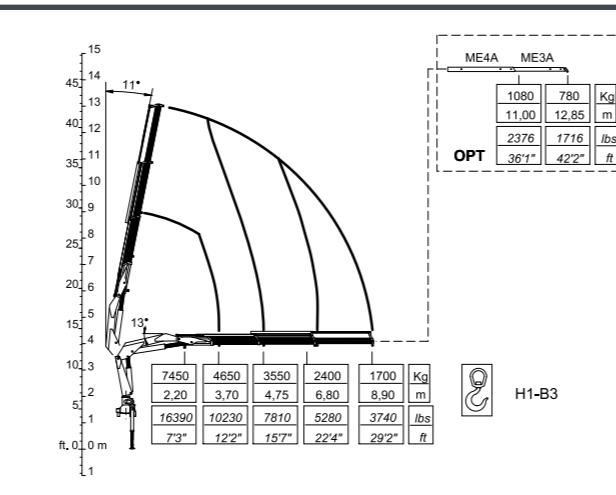

180.4

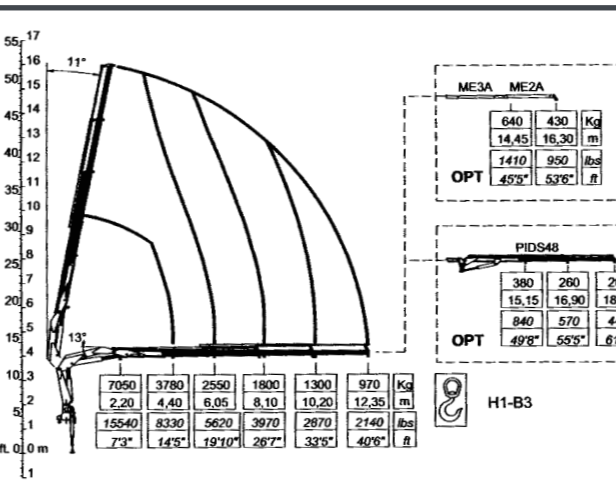

180.5

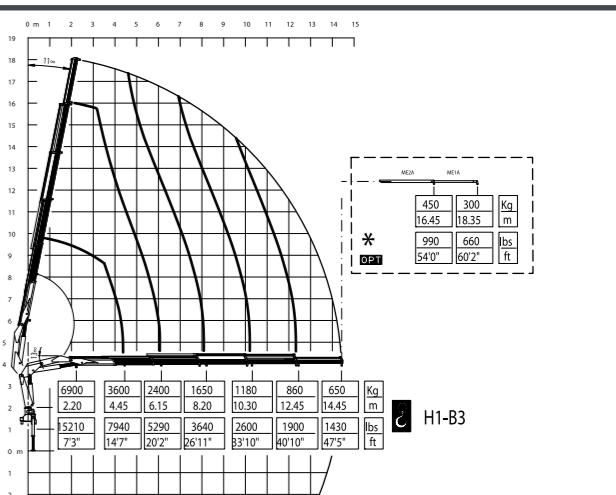

I	F	D	E	P	180.1	180.2	180.3-3SC	180.4-4SC	180.5-5SC	GB	USA	180.1 USA	180.2 USA	180.3-3SC USA	180.4-4SC USA	180.5-5SC USA
Caratteristiche tecniche	Caractéristiques techniques	Technische Eigenschaften	Datos Técnicos	Datos Técnicos						Specifications						
Momento massimo di sollevamento	Couple de levage	Hubmoment	Momento de elevación	Capacidade máxima de elevação	kNm 178,30	kNm 174,30	kNm 167,70	kNm 166,30	kNm 162,65	Lifting moment		lbs.ft 128964	lbs.ft 126071	lbs.ft 121297	lbs.ft 120285	lbs.ft 117.643
Momento massimo dinamico all'asse colonna	Moment maxi. dynamique à l'axe colonne	Max. dynamisches Moment an der Säulenachse	Momento max. dinamico al eje de la columna	Capacidade máxima dinamica no eixo da coluna	daNm 22300	daNm 22300	daNm 22300	daNm 22300	daNm 22300	Maximum dynamic moment at column axis		lbs.ft 161300	lbs.ft 161300	lbs.ft 161300	lbs.ft 161300	lbs.ft 161300
Tempo di rotazione (360°)	Temps de rotation (360°)	Schwenkungszeit (360°)	Tiempo de giro (360°)	Tempo de rotação (360°)	sec. 24	sec. 24	sec. 24	sec. 24	sec. 24	Time of rotation (360°)		sec. 24	sec. 24	sec. 24	sec. 24	sec. 24
Coppia massima di rotazione	Couple maxi. de rotation	Max. Schwenkmoment	Potencia máxima de giro	Binário máximo de rotação	daNm 2280	daNm 2280	daNm 2280	daNm 2280	daNm 2280	Maximum rotation torque		lbs.ft 16491	lbs.ft 16491	lbs.ft 16491	lbs.ft 16491	lbs.ft 16491
Velocità di sollevamento (*)	Vitesse de levage (*)	Hubgeschwindigkeit (*)	Velocidad de elevación (*)	Velocidade de elevação (*)	m/min 23	m/min 33	m/min 41	m/min 51	m/min 61	Lifting speed (*)		ft/min 75'	ft/min 108'	ft/min 134'	ft/min 167'	ft/min 198'
Numero di sezioni del distributore (gru STD)	Nombre des éléments du distributeur (grue STD)	Zahl der Steuerblocksektionen (Standardkran)	Número de las secciones del distribuidor (grúa STD)	Número dos elementos do distribuidor (grua std.)	5	5	5	5	5	Number of distributor section (STD crane)		5	5	5	5	5
Capacità serbatoio olio	Capacité réservoir huile	Fassungsvermögen des Ölbehalters	Capacidad del depósito de aceite	Capacidade do depósito de óleo	l 100	l 100	l 100	l 100	l 100	Oil tank capacity		gal 26.3	gal 26.3	gal 26.3	gal 26.3	gal 26.3
Pressione massima di esercizio (gru CE)	Pression maxi. d'exercice (grue CE)	Max. Betriebsdruck (CE Kran)	Presión máxima de trabajo (grúa CE)	Pressão máxima de trabalho (Grua CE)	bar 310	bar 310	bar 310	bar 310	bar 310	Maximum working pressure (CE crane)		psi 4495	psi 4495	psi 4495	psi 4495	psi 4495
Portata ottimale della pompa	Débit de la pompe	Optimale Fördermenge der Pumpe	Caudal recomendado de la bomba	Capacidade da bomba	l/min 40	l/min 40	l/min 40	l/min 40	l/min 40	Recommended pump delivery		gal/min 10.5	gal/min 10.5	gal/min 10.5	gal/min 10.5	gal/min 10.5
Potenza massima richiesta	Puissance maxi. demandée	Max. Leistung	Potencia máxima demandada	Potência máxima	kW/CV 25/35	kW/CV 25/35	kW/CV 25/35	kW/CV 25/35	kW/CV 25/35	Maximum power required		ft.lbs/s 18520	ft.lbs/s 18520	ft.lbs/s 18520	ft.lbs/s 18520	ft.lbs/s 18520
Tiro massimo verricello (ultimo strato)	Tirage maxi. du treuil (dernière couche)	Max. Zugkraft Seilwinde (letzte Anzahl)	Tiro máximo del cabrestante (última capa)	Força máxima do guincho	daN 1412	daN 1412	daN 1412	daN 1412	daN 1412	Maximum pull of winch (last layer)		lbs 3113	lbs 3113	lbs 3113	lbs 3113	lbs 3113
Massa gru standard	Masse grue standard	Masse des Standardkrans	Peso de la grúa standard	Peso da grua standard	Kg 2050	Kg 2200	Kg 2320	Kg 2450	Kg 2580	Mass of standard crane		lbs 4520	lbs 4850	lbs 5115	lbs 5400	lbs 5700
Massa PIDS48	Masse PIDS48	Masse PIDS48	Peso de PIDS48	Peso de PIDS48		Kg 390	Kg 390	Kg 390		Mass PIDS48			lbs 860	lbs 860	lbs 860	
Prolonghe meccaniche	Rallonges manuelles	Mechanische Verlängerungen	Prolongas mecánicas	Prolongas mecánicas	ME5B, ME4C, ME3C	ME5A, ME4B, ME3B, ME51A, ME50A	ME4A, ME3A, ME51A, ME50A	ME3A, ME2A, ME51A, ME50A	ME3A, ME2A	Manual extensions		ME5B, ME4C, ME3C	ME5A, ME4B, ME3B, ME51A, ME50A	ME4A, ME3A, ME51A, ME50A	ME3A, ME2A, ME51A, ME50A	ME3A, ME2A

180.1 / 2
.3 / 3SC
.4 / 4SC
.5 / 5SC

- 2) Con attivazioni
- 2) Mit Zusatzsteuerungen
- 4) Con prolunga articolata
- 4) Mit Knickarm
- 2) With extra functions
- 2) Con mandos
- 4) With articulated extension
- 4) Con extensión articulada
- 2) Avec activations
- 2) Com activações
- 4) Avec jib
- 4) Com extensão articulada

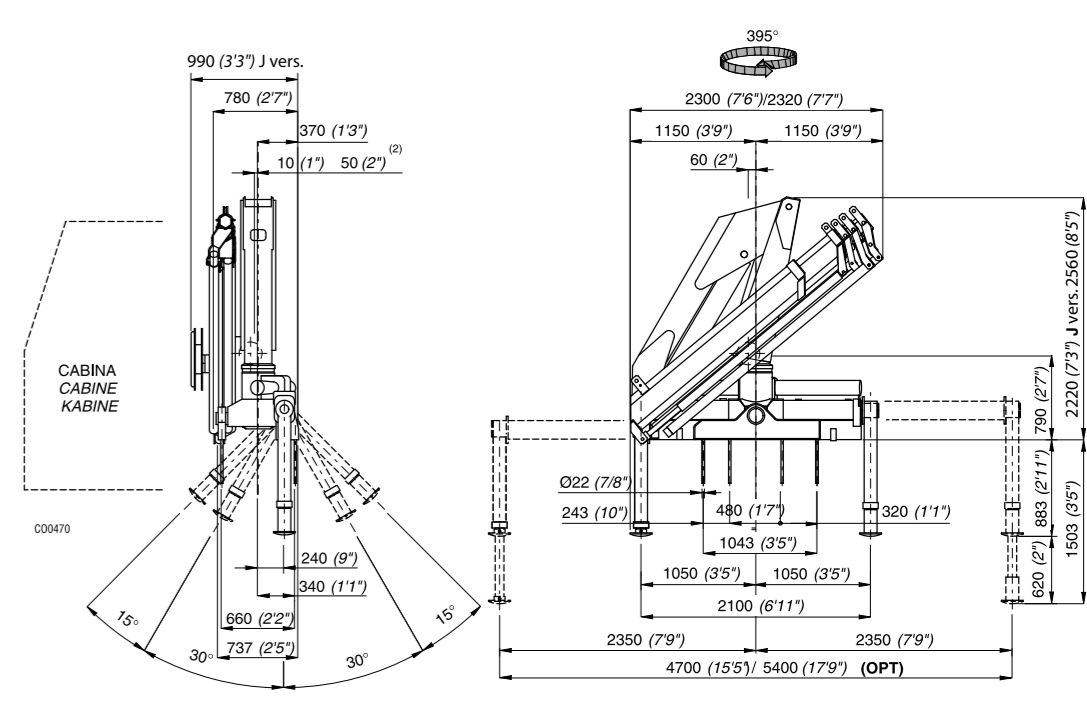

I dati e le descrizioni del presente catalogo sono forniti a titolo indicativo e non sono vincolanti. COPMA 2000 si riserva il diritto di modificarli senza alcun avviso. Technical features are not binding. COPMA 2000 reserves itself the right to any modification without notice.

*E' considerato lo sbraaccio massimo della gru base / *Avec un extension maxi. de la grue de base / *Es handelt sich um die max. Ausladung des Standardkrans / *Se considera el alcance max. de la grúa std / *Se considera el alcance max. de la grúa std / *The maximum range of the basic crane is considered